

# DLK 170 DP



Square recessed luminaire. Top quality SMD LED module with colour consistency MacAdams  $\leq 3$ , extensive portfolio of lumen ranges, CCTs and spectra. Variety of drivers: standard EVG on/off, DALI and wireless controlled as MasterConnect or Casambi on request. Built-in or remote, wireless occupancy & daylight sensor available to allow significant energy savings and wireless connectivity. Mounting into any type of suspended ceiling. Body is made of aluminium and steel. Standard colour RAL 9003M any other colour from basic RAL range available at no extra cost. Selection of lumen outputs and drivers allows to use this luminaire in different types of lighting projects.

Luminous flux & Luminaire Power tolerance up to 10%. System power consumption depends on components used. Luminous efficacy depends on type of LED's, electronics, optics and diffusor. The most up to date technical parameters can be found on our website and in database of LDT files.

Lighting direction:



PDF datasheet:



# DLK 170 DP

<b>Mounting:</b>	Recessed mounting
<b>Body material:</b>	Steel and aluminium
<b>Colour:</b>	Standard white RAL 9003M, other RAL colours on request
<b>Lumen output:</b>	Standard up to 2000 lm, any other on request
<b>LED module:</b>	Signify (Philips), Tridonic or equivalent SMD LED module
<b>Colour temperature:</b>	3000/4000K, other on request
<b>Colour Rendering:</b>	CRI>80 in standard, other on request
<b>Driver:</b>	EVG integrated on-off/ EVG on-off/DALI/MC ( MasterConnect )/Casambi, other on request
<b>Wireless control:</b>	Philips MasterConnect / Casambi, other on request
<b>Daylight/Occupancy sensor:</b>	Wireless MCS sensor
<b>Emergency unit:</b>	On request
<b>Operating temperature range:</b>	0°C ... +35°C
<b>IP Class:</b>	IP44 in standard
<b>Power:</b>	220-240V 50/60Hz
<b>Lighting direction:</b>	Direct
<b>Light distribution:</b>	Symmetric
<b>Optics:</b>	N/A
<b>Beam angle:</b>	All types available in our LDT file database
<b>Diffusor:</b>	OP white acrylic
<b>Warranty:</b>	5 Years standard warranty

**DLK 170 DP** recessed mounted, light down

All current index numbers, lumen outputs, power consumption and many other technical information are available in our 2024 pricelist. Details on wireless lighting control systems on page number 896.



Energy saving MasterConnect wireless lighting control system with daylight and movement detection technology on request.



MCS wireless daylight&occ sensor



XCS wireless switch

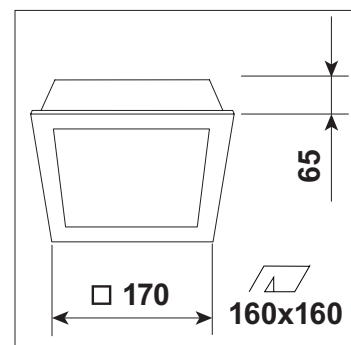

Basic dimensions



## DLK 170 DP

Product code	Product name	Gross Lumen [lm]	Nett Lumen [lm]	Power [W]	Efficacy [lm/W]	Colour temperature [K]	Optics	Length [mm]	Width [mm]	Height [mm]	Nett Weight [kg]
40.02340.83.E.OP	DLK 170 DP / 1100lm / 830 / E / OP	1100	990	9	110	3000	Symmetrical	170	170	70	0,9
40.02340.84.E.OP	DLK 170 DP / 1100lm / 840 / E / OP	1100	990	9	110	4000	Symmetrical	170	170	70	0,9
40.02341.83.E.OP	DLK 170 DP / 2000lm / 830 / E / OP	2000	1800	17	106	3000	Symmetrical	170	170	70	0,9
40.02341.84.E.OP	DLK 170 DP / 2000lm / 840 / E / OP	2000	1800	17	106	4000	Symmetrical	170	170	70	0,9